

## Duke Energy - EPRI DC Powered Data Center Demonstration Executive Summary

**What:** Duke Energy and EPRI Sponsored DC Powered Data Center Demonstration Using 380V DC Power  
**When:** 2010-2011  
**Where:** Duke Energy Data Center, Charlotte, North Carolina

### Overview

Typical data center power delivery designs use alternating current (AC) power, typically distributed within the facility at 480V AC. Direct current (DC) power distribution is an alternative approach to a conventional data center AC power scheme. Duke Energy and the Electric Power Research Institute (EPRI) are working together in a demonstration project that focuses on DC conversion at the data center (or facility) level. The approach will convert the facility's 480V AC into 380V DC and deliver it to the equipment racks via a 380V DC bus. The very best AC equipment can be deployed to improve power distribution efficiency, but that approach only squeezes some of the losses out of each component. The DC approach eliminates those losses completely, through the removal of the less efficient AC components.

Through this demonstration, it is expected that the Duke Energy data center should yield anywhere from 7 to 20 percent energy savings, depending on the vintage of the equipment compared. These figures could be doubled if you take into account the added energy savings realized by the decrease in cooling load.

### Preliminary Results Synopsis

Testing of a direct current power system at a Duke Energy data center in Charlotte, North Carolina has revealed preliminary results that the system uses 15 percent less energy than a typical double conversion UPS alternating current power system.

### Background

Typical data center power delivery designs use alternating current (AC) power, typically distributed within the facility at 480V AC. This power goes through several conversions from AC to DC and back again. The power losses due to the use of inefficient power conversion devices from both outside and within equipment result in a large loss of useful electrical power, as well as directly increasing the energy required to remove the heat produced. While estimates and actual measurements vary, the actual power utilization by IT loads can sometimes be as low as 50 percent of the total input power consumption, or worse.

DC power distribution is an alternative approach to a conventional data center AC power scheme. Most data center server racks are not currently powered using DC, but the servers and storage arrays can operate with either AC or DC. Typical servers and storage arrays inherently convert an AC power source to DC within each power supply which adds an additional power conversion loss within the typical data center power chain. Using the DC powering approach, extra power conversion steps are eliminated creating several benefits, mainly:

- Lowering losses,
- Increasing reliability,

Together . . . Shaping the Future of Electricity

#### PALO ALTO OFFICE

3420 Hillview Avenue, Palo Alto, CA 94304-1395 USA • 650.855.2000 • Customer Service 800.313.3774 • [www.epri.com](http://www.epri.com)

- Reduced cooling needs,
- Higher equipment densities equaling lower square footage requirements for data centers,
- Simpler power supplies, and
- Reduced heat-related failures.

DC power distribution has been experimented with by several prominent companies including IBM, Sun Microsystems, NTT (Japan), NetPower (Sweden) and the Intel Corp. As this innovative technique becomes more prevalent in the market place, manufacturers are beginning to create products capable of utilizing these higher DC voltages.

## **Demonstration Goal and Objectives**

A joint effort between Duke Energy and EPRI to investigate:

1. Retrofitting selected data center computer hardware to operate on 380V DC power and compare the efficiency and reliability to the same set of hardware powered by 208V AC power.
2. Document the data center facility efficiency gains from the elimination of multiple conversion steps in the delivery of server power.
3. Determine the feasibility for DC conversion and delivery.
4. Identify issues/best practices and make recommendations for further implementation.
5. Leverage the results of this study to drive out a common set of DC power standards.

This demonstration also involves the participation of a number of companies. They include:

- Delta Products Corporation has provided the 380VDC rectifiers and many of the 380VDC power supplies
- Hewlett Packard has provided ten DL 385 G7 servers
- IBM has provided the IBM Power795 server
- EMC has provided the CLARION CX4-960 storage array
- Direct Power Technologies, Inc. has provided the design work to interconnect all of the equipment
- Universal Electric Corporation has supplied the StarLine Plug-in Busway and circuit drops

## **DC Data Center Demonstration**

This demonstration project focuses on DC conversion at the data center (or facility) level. The approach converts the facility's 480V AC into 380V DC and delivers it to the equipment racks via a 380V DC bus. At a high level, 3 racks will be run on AC or DC, with the ability to switch between the two sources. Each rack will be metered providing comparative data to be collected and analyzed.

The concept concentrates the DC conversion into one unit/location, removing the multiple AC to DC conversions. This demonstration will take this approach for a small portion of the Duke facility. The figure below shows the test setup.

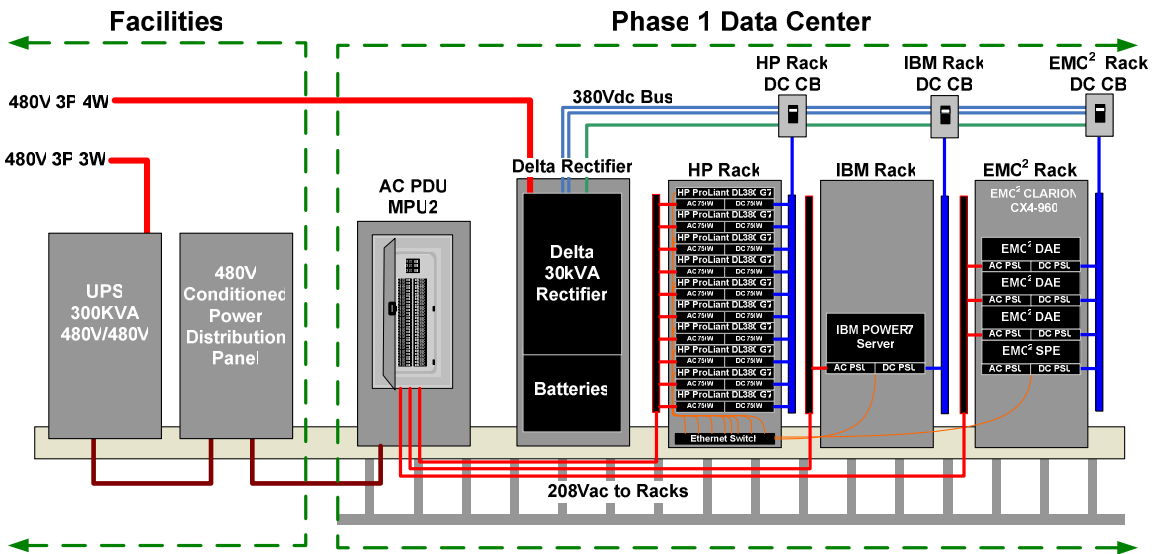

## Expected Results

A detailed study by Intel and other industry leaders of the power distribution industry performed a comparison of three systems – the first one is a baseline 480V AC system, the second one is a 480V AC system with the best efficiency available in the market, and the third is a 380V DC system. The table below shows the efficiency of each system and how these values impact the input power for a computer load of 100kW. While the high efficiency AC system can effect a 25 percent improvement, going to DC can be even better. In addition, the high efficiency AC system assumes cost is not a barrier, when in fact the DC system can be less costly. In the study, the DC system was shown to achieve a cost savings of 15 percent compared to the typical AC system.

System Type	Total System Efficiency	Compute Power (W)	Input Power (W)		Difference
Typical Efficiency	51.17%	100,000	195445.29		
High Efficiency AC	67.87%	100,000	147349.91	Hi Eff AC vs Typical	24.61%
DC Option	72.04%	100,000	138818.18	DC vs Typical	28.97%
				DC vs High Eff AC	5.79%

In addition to this theoretical study, a field experiment by EPRI, LBNL, Ecos Consulting, Sun and Intel yielded similar results. The overall improvement over the **high** efficiency system was measured at about a 7 percent reduction in power use. Compared to legacy components, the measured improvement was 28 percent. Based on this background data, it is expected that the Duke demonstration should yield anywhere from 7 to 20 percent energy savings, depending on the vintage of the equipment compared. These figures do not include the added energy saving realized by the decrease in cooling load.

## Preliminary Results

Parameter	Average	Max	Min	Standard Deviation
UPS Load Factor	29.8%	30.0%	29.7%	0.001
Rectifier Load Factor	30.5%	30.7%	30.4%	0.001
Unconditioned Power Rectifier	9.206	9.278	9.185	0.020
Unconditioned Power Required at UPS Input	10.851	10.888	10.823	0.019
Percentage Difference Less than AC Network	15.2%	14.8%	15.1%	
Average (Standard Deviation)				0.010

## Perspective on Preliminary Results

Preliminary test results are very promising. Early findings show that some of the more inefficient data centers could realize on average a 15 percent reduction in server energy consumption. And by reducing the usage of the servers the facility could also reduce the amount of heat generated – potentially resulting in an equal amount of reduced air conditioning load.

While this is significant news for any company running a data center today, this could be especially critical for the more than 2.5 million smaller data centers across the United States that rely upon inexpensive yet viable ways to reduce costs. In many cases the data centers and the associated energy usage are simply considered a fixed cost, nearly impossible to reduce with cost-effective measures. Curtis Watkins, who works in Duke Energy's Chief Technology Office as part of the DC server power test team, recalls such an experience while working at a start up back in the early 2000s. "Our organization was always looking at ways to control costs, but one area we rarely bothered to look was the server room. Our team assumed the electricity consumed and the air conditioning units almost constant run came with the territory. Short of replacing the servers every couple of years with newer more efficient models, which was not feasible, our team just went with it because of the critical nature of our data operations" he said. "However, had there been at the time a simple option like what is being demonstrated in this test here in Duke's facilities I can say we would have jumped at the opportunity."

If this DC technology was to be utilized across all of the 2.5 million operations similar in size and scale, the impact could be significant, where on average there is almost a 3 MW energy consumption per year to run a single data center. Assume that with this technology those 2.5 million data centers could on average realize an 18 percent energy efficiency savings (based on the test results from the Duke facilities). Across the board there is the potential for an average annual savings close to 1.25 million MW, which is enough electricity to power almost 18,000 homes for an entire year.

## About EPRI

The Electric Power Research Institute, Inc. (EPRI, [www.epri.com](http://www.epri.com)) conducts research and development relating to the generation, delivery and use of electricity for the benefit of the public. An independent,

nonprofit organization, EPRI brings together experts from academia and industry as well as its own scientists and engineers to help address challenges in electricity generation, delivery and use, including health, safety and the environment. EPRI's members represent more than 90 percent of the electricity generated and delivered in the United States, and international participation extends to 40 countries. EPRI's principal offices and laboratories are located in Palo Alto, Calif.; Charlotte, N.C.; Knoxville, Tenn.; and Lenox, Mass.

### **About Duke Energy**

Duke Energy is one of the largest electric power holding companies in the United States. Its regulated utility operations serve approximately 4 million customers located in five states in the Southeast and Midwest, representing a population of approximately 11 million people. Its commercial power and international business segments own and operate diverse power generation assets in North America and Latin America, including a growing portfolio of renewable energy assets in the United States. Headquartered in Charlotte, N.C., Duke Energy is a Fortune 500 company traded on the New York Stock Exchange under the symbol DUK. More information about the company is available on the Internet at: <http://www.duke-energy.com/>.

###

Contact:

Don Kintner  
EPRI  
Manager, Communications  
[dkintner@epri.com](mailto:dkintner@epri.com)  
704-595-2006